

X100/301

NATIONAL
QUALIFICATIONS
2004

FRIDAY, 21 MAY
9.00 AM – 10.10 AM

MATHEMATICS
HIGHER

Units 1, 2 and 3

Paper 1

(Non-calculator)

Read Carefully

- 1 Calculators may **NOT** be used in this paper.
- 2 Full credit will be given only where the solution contains appropriate working.
- 3 Answers obtained by readings from scale drawings will not receive any credit.



FORMULAE LIST

Circle:

The equation $x^2 + y^2 + 2gx + 2fy + c = 0$ represents a circle centre $(-g, -f)$ and radius $\sqrt{g^2 + f^2 - c}$.

The equation $(x - a)^2 + (y - b)^2 = r^2$ represents a circle centre (a, b) and radius r .

Scalar Product: $\mathbf{a} \cdot \mathbf{b} = |\mathbf{a}| |\mathbf{b}| \cos \theta$, where θ is the angle between \mathbf{a} and \mathbf{b}

or $\mathbf{a} \cdot \mathbf{b} = a_1 b_1 + a_2 b_2 + a_3 b_3$ where $\mathbf{a} = \begin{pmatrix} a_1 \\ a_2 \\ a_3 \end{pmatrix}$ and $\mathbf{b} = \begin{pmatrix} b_1 \\ b_2 \\ b_3 \end{pmatrix}$.

Trigonometric formulae: $\sin(A \pm B) = \sin A \cos B \pm \cos A \sin B$

$$\cos(A \pm B) = \cos A \cos B \mp \sin A \sin B$$

$$\sin 2A = 2 \sin A \cos A$$

$$\cos 2A = \cos^2 A - \sin^2 A$$

$$= 2 \cos^2 A - 1$$

$$= 1 - 2 \sin^2 A$$

Table of standard derivatives:

$f(x)$	$f'(x)$
$\sin ax$	$a \cos ax$
$\cos ax$	$-a \sin ax$

Table of standard integrals:

$f(x)$	$\int f(x) dx$
$\sin ax$	$-\frac{1}{a} \cos ax + C$
$\cos ax$	$\frac{1}{a} \sin ax + C$

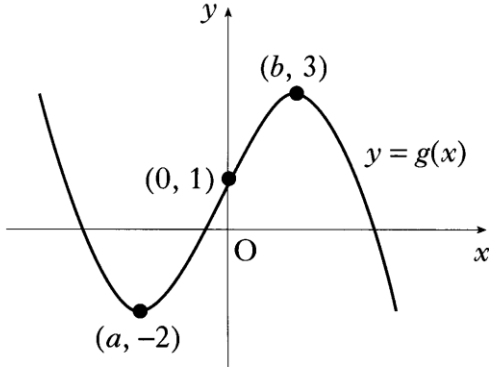
1. The point A has coordinates (7, 4). The straight lines with equations $x + 3y + 1 = 0$ and $2x + 5y = 0$ intersect at B.
- (a) Find the gradient of AB. 3
- (b) Hence show that AB is perpendicular to only one of these two lines. 5
2. $f(x) = x^3 - x^2 - 5x - 3$.
- (a) (i) Show that $(x + 1)$ is a factor of $f(x)$.
 (ii) Hence or otherwise factorise $f(x)$ fully. 5
- (b) One of the turning points of the graph of $y = f(x)$ lies on the x -axis. Write down the coordinates of this turning point. 1
3. Find all the values of x in the interval $0 \leq x \leq 2\pi$ for which $\tan^2(x) = 3$. 4
4. The diagram shows the graph of $y = g(x)$.
- (a) Sketch the graph of $y = -g(x)$. 2
- (b) On the same diagram, sketch the graph of $y = 3 - g(x)$. 2
- 
5. A, B and C have coordinates $(-3, 4, 7)$, $(-1, 8, 3)$ and $(0, 10, 1)$ respectively.
- (a) Show that A, B and C are collinear. 3
- (b) Find the coordinates of D such that $\vec{AD} = 4\vec{AB}$. 2
6. Given that $y = 3\sin(x) + \cos(2x)$, find $\frac{dy}{dx}$. 3

[Turn over for Questions 7 to 11 on Page four

7. Find $\int_0^2 \sqrt{4x+1} \, dx$.

5

8. (a) Write $x^2 - 10x + 27$ in the form $(x + b)^2 + c$.

2

(b) Hence show that the function $g(x) = \frac{1}{3}x^3 - 5x^2 + 27x - 2$ is always increasing.

4

9. Solve the equation $\log_2(x + 1) - 2\log_2(3) = 3$.

4

10. In the diagram
 angle $DEC = \text{angle } CEB = x^\circ$ and
 angle $CDE = \text{angle } BEA = 90^\circ$.
 $CD = 1$ unit; $DE = 3$ units.
 By writing angle DEA in terms
 of x° , find the exact value of
 $\cos(\hat{DEA})$.

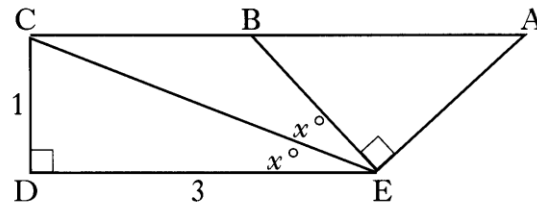

7

11. The diagram shows a parabola passing through the points $(0, 0)$, $(1, -6)$ and $(2, 0)$.

- (a) The equation of the parabola is of the form $y = ax(x - b)$.

Find the values of a and b .

- (b) This parabola is the graph of $y = f'(x)$.
 Given that $f(1) = 4$, find the formula for $f(x)$.

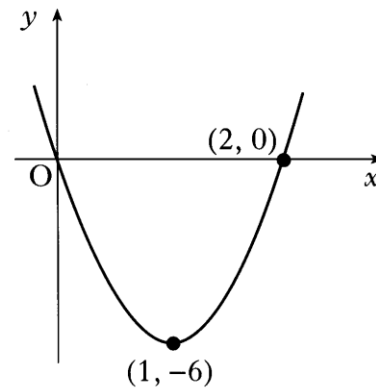

3

5

[END OF QUESTION PAPER]

X100/303

NATIONAL
QUALIFICATIONS
2004

FRIDAY, 21 MAY
10.30 AM – 12.00 NOON

MATHEMATICS
HIGHER
Units 1, 2 and 3
Paper 2

Read Carefully

- 1 **Calculators may be used in this paper.**
- 2 Full credit will be given only where the solution contains appropriate working.
- 3 Answers obtained by readings from scale drawings will not receive any credit.



FORMULAE LIST

Circle:

The equation $x^2 + y^2 + 2gx + 2fy + c = 0$ represents a circle centre $(-g, -f)$ and radius $\sqrt{g^2 + f^2 - c}$.

The equation $(x - a)^2 + (y - b)^2 = r^2$ represents a circle centre (a, b) and radius r .

Scalar Product: $\mathbf{a} \cdot \mathbf{b} = |\mathbf{a}| |\mathbf{b}| \cos \theta$, where θ is the angle between \mathbf{a} and \mathbf{b}

or $\mathbf{a} \cdot \mathbf{b} = a_1 b_1 + a_2 b_2 + a_3 b_3$ where $\mathbf{a} = \begin{pmatrix} a_1 \\ a_2 \\ a_3 \end{pmatrix}$ and $\mathbf{b} = \begin{pmatrix} b_1 \\ b_2 \\ b_3 \end{pmatrix}$.

Trigonometric formulae: $\sin(A \pm B) = \sin A \cos B \pm \cos A \sin B$

$$\cos(A \pm B) = \cos A \cos B \mp \sin A \sin B$$

$$\sin 2A = 2 \sin A \cos A$$

$$\cos 2A = \cos^2 A - \sin^2 A$$

$$= 2 \cos^2 A - 1$$

$$= 1 - 2 \sin^2 A$$

Table of standard derivatives:

$f(x)$	$f'(x)$
$\sin ax$	$a \cos ax$
$\cos ax$	$-a \sin ax$

Table of standard integrals:

$f(x)$	$\int f(x) dx$
$\sin ax$	$-\frac{1}{a} \cos ax + C$
$\cos ax$	$\frac{1}{a} \sin ax + C$

ALL questions should be attempted.

Marks

1. (a) The diagram shows line OA with equation $x - 2y = 0$.
The angle between OA and the x -axis is a° .
Find the value of a .

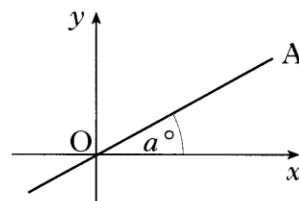

3

- (b) The second diagram shows lines OA and OB. The angle between these two lines is 30° .
Calculate the gradient of line OB correct to 1 decimal place.

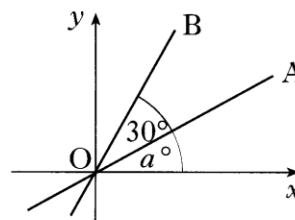

1

2. P, Q and R have coordinates $(1, 3, -1)$, $(2, 0, 1)$ and $(-3, 1, 2)$ respectively.

(a) Express the vectors \vec{QP} and \vec{QR} in component form.

2

(b) Hence or otherwise find the size of angle PQR.

5

3. Prove that the roots of the equation $2x^2 + px - 3 = 0$ are real for all values of p . 4

4. A sequence is defined by the recurrence relation $u_{n+1} = ku_n + 3$.

(a) Write down the condition on k for this sequence to have a limit.

1

(b) The sequence tends to a limit of 5 as $n \rightarrow \infty$. Determine the value of k .

3

5. The point P(x, y) lies on the curve with equation $y = 6x^2 - x^3$.

(a) Find the value of x for which the gradient of the tangent at P is 12.

5

(b) Hence find the equation of the tangent at P.

2

[Turn over

6. (a) Express $3 \cos(x^\circ) + 5 \sin(x^\circ)$ in the form $k \cos(x^\circ - a^\circ)$ where $k > 0$ and $0 \leq a \leq 90$. 4
- (b) Hence solve the equation $3 \cos(x^\circ) + 5 \sin(x^\circ) = 4$ for $0 \leq x \leq 90$. 3

7. The graph of the cubic function $y = f(x)$ is shown in the diagram. There are turning points at $(1, 1)$ and $(3, 5)$. Sketch the graph of $y = f'(x)$. 3

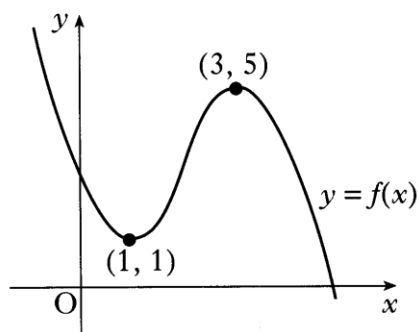

8. The circle with centre A has equation $x^2 + y^2 - 12x - 2y + 32 = 0$. The line PT is a tangent to this circle at the point $P(5, -1)$.

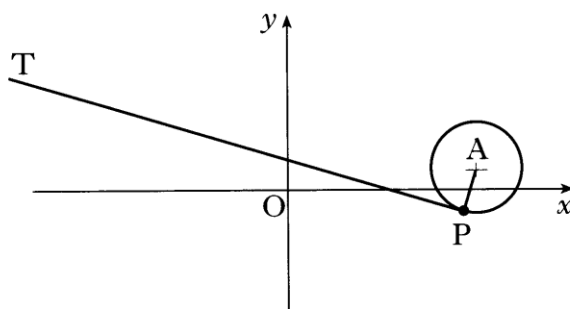

- (a) Show that the equation of this tangent is $x + 2y = 3$. 4

The circle with centre B has equation $x^2 + y^2 + 10x + 2y + 6 = 0$.

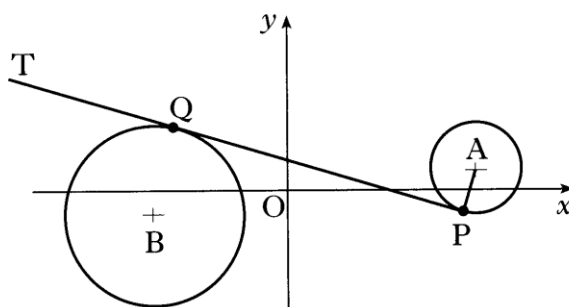

- (b) Show that PT is also a tangent to this circle. 5
- (c) Q is the point of contact. Find the length of PQ. 2

9. An open cuboid measures internally x units by $2x$ units by h units and has an inner surface area of 12 units².

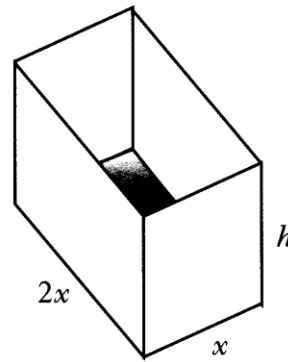

- (a) Show that the volume, V units³, of the cuboid is given by $V(x) = \frac{2}{3}x(6 - x^2)$. **3**
 (b) Find the exact value of x for which this volume is a maximum. **5**

10. The amount A_t micrograms of a certain radioactive substance remaining after t years decreases according to the formula $A_t = A_0 e^{-0.002t}$, where A_0 is the amount present initially.

- (a) If 600 micrograms are left after 1000 years, how many micrograms were present initially? **3**
 (b) The half-life of a substance is the time taken for the amount to decrease to half of its initial amount. What is the half-life of this substance? **4**

11. An architectural feature of a building is a wall with arched windows. The curved edge of each window is parabolic.

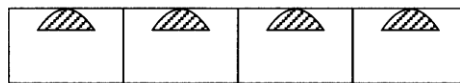

The second diagram shows one such window. The shaded part represents the glass.

The top edge of the window is part of the parabola with equation $y = 2x - \frac{1}{2}x^2$.

Find the area in square metres of the glass in one window.

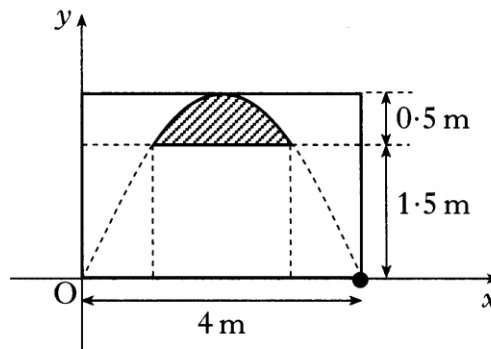

8

[END OF QUESTION PAPER]